

# REINVENTING AV MOUNTS



**World's First  
No-Touch Mount**



# CONTACT

📍 Austria | Netherlands | USA: Nevada & New York | Hong Kong | Vietnam

🌐 [www.AlpsAV.com](http://www.AlpsAV.com) ✉ [contact@AlpsAV.com](mailto:contact@AlpsAV.com) 📞 EU +43 5572 424 053 📞 USA +1 800 363 2918

# Preventing Pressure Damage

## White Paper summary

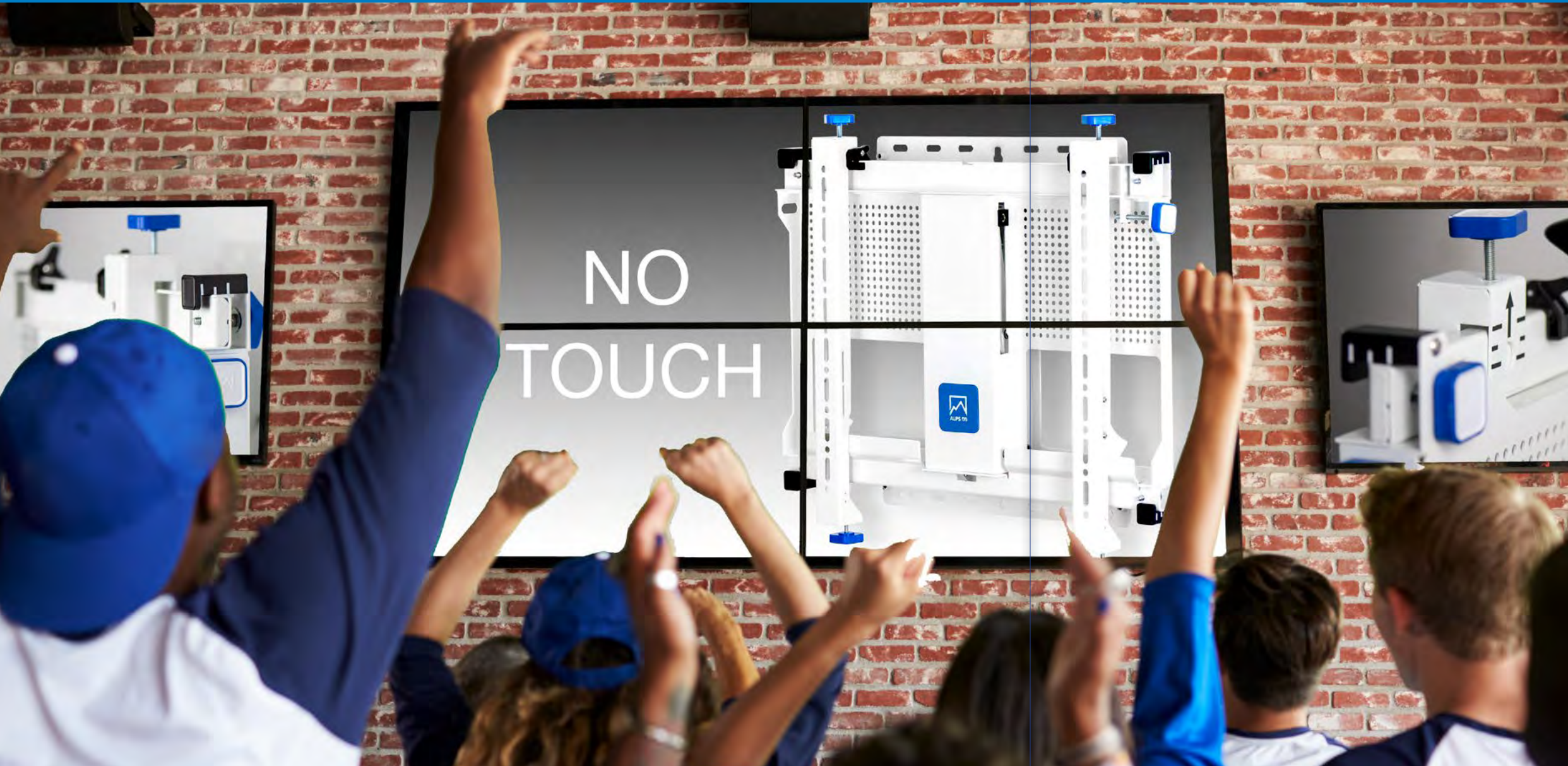

The challenge for Mount Manufacturers is ensuring quick and easy access to the individual screens for adjustments and servicing, while reducing as completely as possible, any risk of damage to the screen or adjacent screens.

Many screen manufacturers will limit or reject warranty claims where any suggestion of pressure being applied to the screen seems to have occurred. This results in the installer assuming significant risk during the installation and servicing and caution must be of primary importance.

In the last decade, since the “pop-out” style mount arrived on the market, the mounts have not changed significantly, however, screens have. Resolutions were in the region of 720 x 480 only 6 years ago, while today, 8k screens boast resolutions of 7,680 x 4,320 dpi. Bezels on digital signage screens were commonly over 0.3” (7mm), just recently (4th quarter 2018) LG launched a 1/60” (0.44mm) bezel.

Repeatedly applying this pressure on the screen or bezel, commonly required when the video wall is being installed, can lead to reduced screen life, pressure damage (permanent pressure marks), cracks or breaking of the screen itself.

Unfortunately, once it is damaged by pressure, a flat screen cannot be fixed. Given how common this kind of damage is, it will come as no surprise that most of the leading manufacturers don't include repairs or replacement from such damage under their product warranties. Therefore, the installer must assume the cost of replacement, if their flat screen display is damaged by pressure or cracked during installation or servicing.

AlpsAV has pioneered new mounting solutions that significantly reduce or even eliminate completely the need to apply any pressure to screens.

**For the complete AlpsAV White Paper please see our website [www.AlpsAV.com](http://www.AlpsAV.com) or contact us and we will send the report to you.**



New York

Netherlands

Nevada

Austria

Vietnam

Hong Kong

# No-Touch Wall Mount

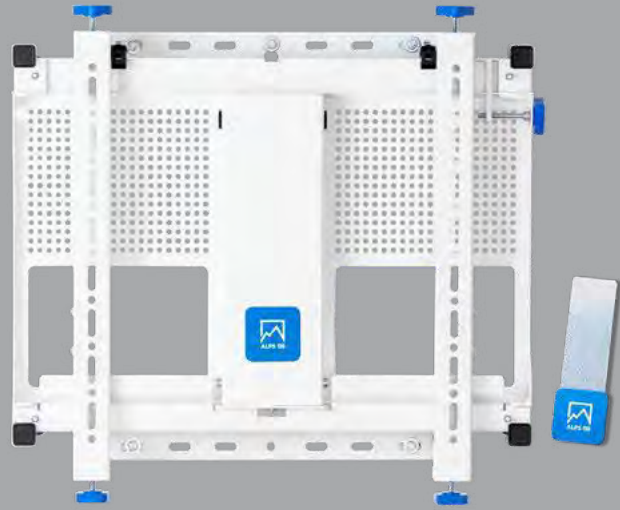

AlpsAV introduces the No-Touch Mount, patent pending innovation for digital signage screens.

Effortlessly, move the screen Out, In, Stop and Reverse with the ultra-thin universal controller. One controller works with all AlpsAV No-Touch Mounts – making it quick and easy to service any screen in the display – no need to figure out which cord to pull or how to access the screen.

Simply slide the controller (0.016" / 0.4mm) below the screen and get to work. The 8-point micro-adjustments, large comfortable handwheels and high contrast White finish save you time and effort.

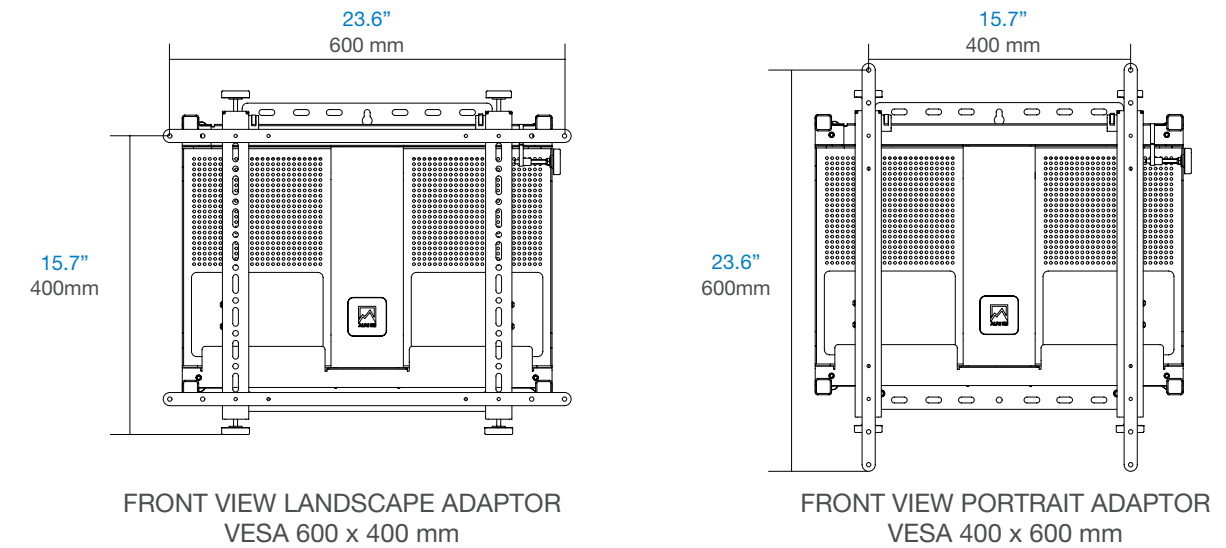
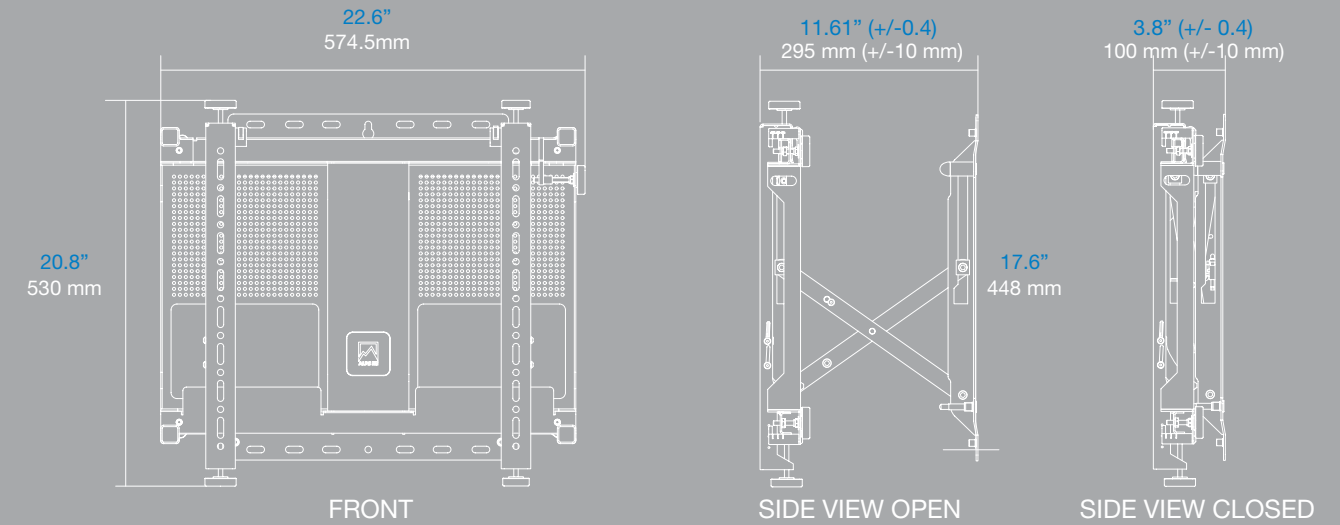

- Patent pending No-Touch digital signage mount.
- Move IN, OUT, STOP and REVERSE, as you choose.
- No-Touch reduces risk of damaging screen, and no fingerprints to clean.
- 8-point Micro-Adjust using large, comfortable hand wheels, no tools required.
- White finish increases contrast and visibility for faster and easier installations.
- Impact detection for additional safety.
- Redundant back-up release for extreme reliability.

- Central X-arm design makes side access open and easy, increasing available wall space.
- Simply power-off to lock in position.
- Portrait or Landscape orientation.
- All screen mounting hardware and spacers included.
- Equipment rack built in for easy accessory connections.
- VESA 600 x 400mm (P) or 400 x 600mm (L) adaptor included.
- 46" screens and larger up to 40kgs/90lbs.

**Model Number: AV01**

**Product Specifications:**

Dimensions (WxHxD): 22.6" x 20.8" x 3.8"  
574.5 x 530 x 97.5mm

Product weight: 29lbs / 13kgs

Load Capacity: 90lbs / 44kgs

Finish: Powder Coat

Color: White

**Package Specifications:**

Package size (WxHxD) 26" x 23" x 4.75"  
650 x 575 x 120mm

Package ship weight: 32lbs / 14.5kgs

Package content: 1 No-Touch Mount

Units in package: 1 Each



CUSTOM ELECTRONIC DESIGN & INSTALLATION ASSOCIATION

# Soft-Touch Wall Mount

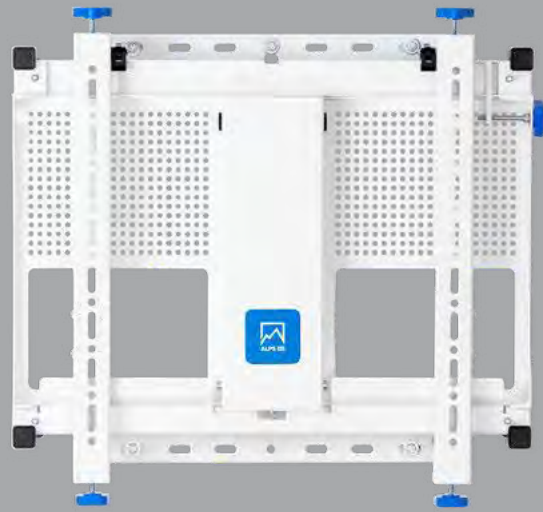

The Soft-Touch Mount from AlpsAV significantly reduces the pressure required to open and close screens. Less pressure reduces the risk of damage to the screen as resolutions increase and bezels decrease. With no release to pull, you can easily access, open and close screens in Video Walls or recessed openings.

Our central X-arm design allows easy access to the screen and increases available wall space. The White finish improves the contrast between the screen, accessories, cables and the mount. With 8-point tool-less micro-adjustment using large comfortable handwheels, full screen fixing kit, Portrait (VESA 400 x 600mm) and Landscape (VESA 600 x 400mm) screen orientation, mounting weights up to 40kgs/90lbs. AlpsAV and the Soft-Touch Mount save time and money, now and in the future.

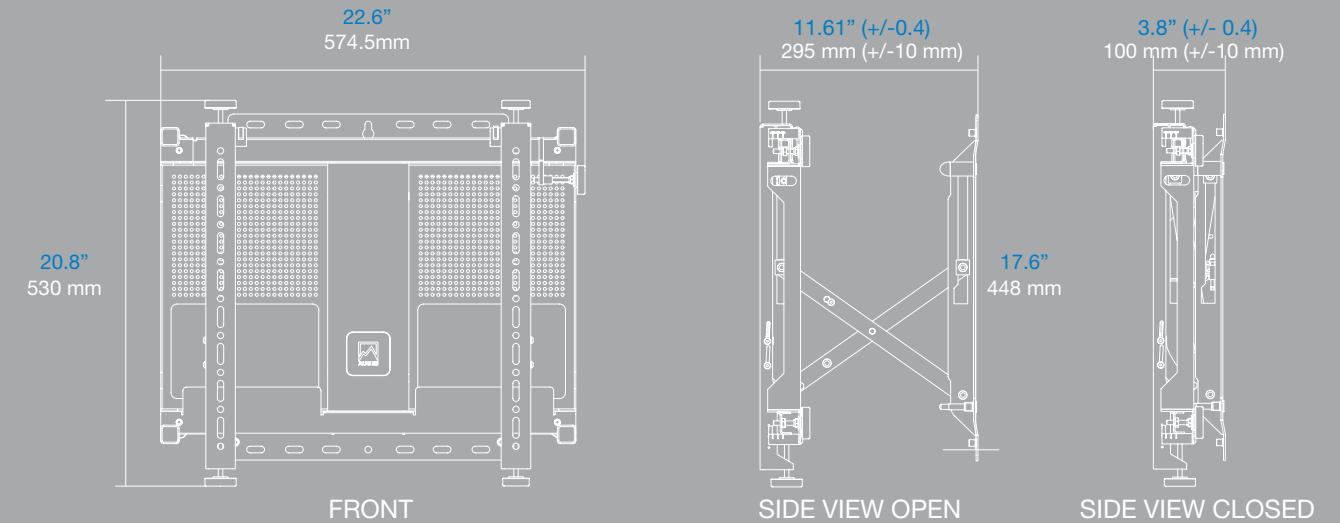

- Easy Open & Close
- 8-point Micro-Adjust
- Quick-Lock Lateral-Adjust
- Large Hand Wheels
- White Finish
- Landscape or Portrait

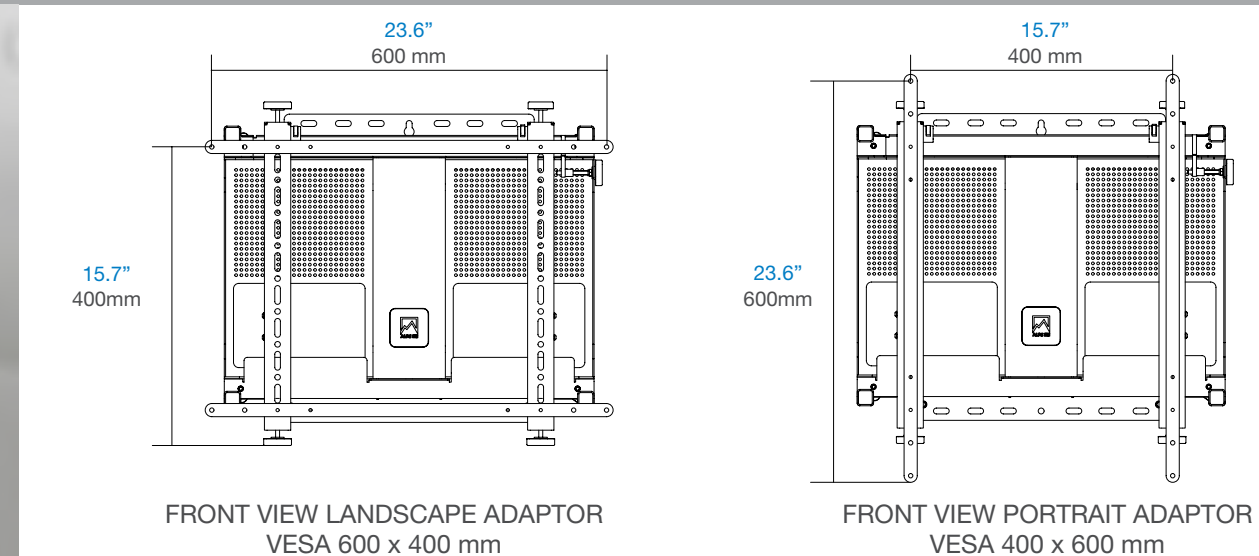

- Soft -Touch Mount significantly reduces the pressure applied to the screen for opening and closing.
- Micro-Adjustments for all corners, lateral and height adjustments.
- White finish increases contrast between components and cables, making installation faster.
- Smooth, large handwheels are comfortable and easy to use.
- Centrally located X-arm, makes side access open and easy, increasing available wall space.
- Portrait or Landscape orientation.
- All screen mounting hardware and spacers included.
- Equipment rack for easy accessory connections, included.
- Extension arms for VESA 600 x 400 mm or 400 x 600 mm included.
- 46" screens and larger up to 40kgs/90lbs.

**Model Number: AV02**

**Product Specifications:**

Dimensions (WxHxD): 22.6" x 20.8" x 3.8"  
574.5 x 530 x 97.5mm

Product weight: 27lbs / 12kgs

Load Capacity: 90lbs / 44kgs

Finish: Powder Coat

Color: White

**Package Specifications:**

Package size (WxHxD) 26" x 23" x 4.75"  
650 x 575 x 120mm

Package ship weight: 29lbs / 13kgs

Package content: 1 Soft-Touch Mount

Units in package: 1 Each



# ABOUT

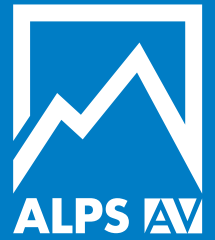

## What Happens

when an ambitious Expert of the Pro AV Mounts business meets the Entrepreneurial owner of a Austrian company with over 25 years' experience in industrial high-tech automation?

## “Why Does

the mount business fail to innovate”, asks the owner, “given screens and digital signage technologies are always creating new and better products?” The expert replies “Many companies have been around for years and are too busy copying each other! While Video Wall displays are constantly evolving with higher resolutions, smaller bezels, and the manufactures constantly warn about pressure damage and not touching the screen, the mount companies tell you, push to Open and/or Close!”

## “When Will

a smart No-Touch mount be available on the market?” asks the owner. “As soon as you develop one, patent it, and prove to me that it works!” says the expert.

A few months later...

## “How Do

we now go to market with our product, we have world class manufacturing and engineering, as you can see from the sample, so let's proceed.” states the owner. They then go on to discuss how to also use innovative approaches for all aspects of the new business.

# REVOLUTIONIZE THE MARKET

World Class, High-Tech, innovation and unbelievably great prices...

## That's AlpsAV

