

INSTALLATION INSTRUCTIONS

FIX TROLLEY

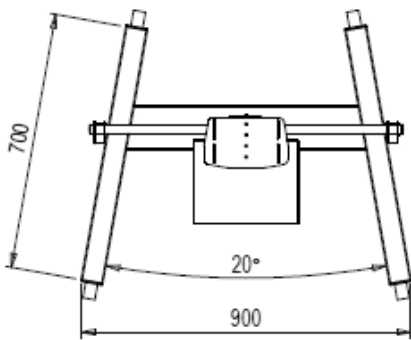
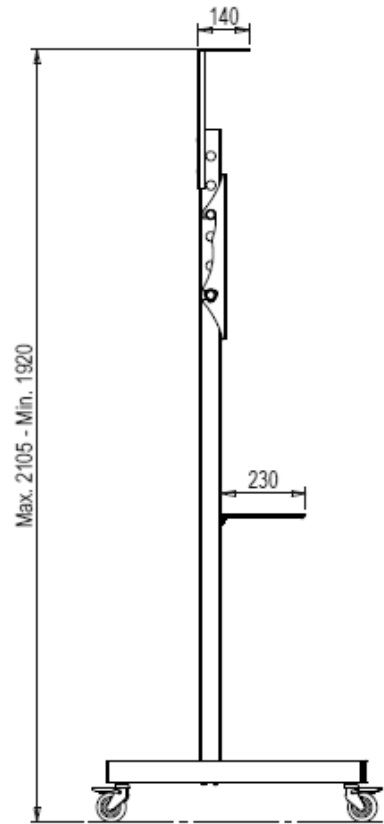
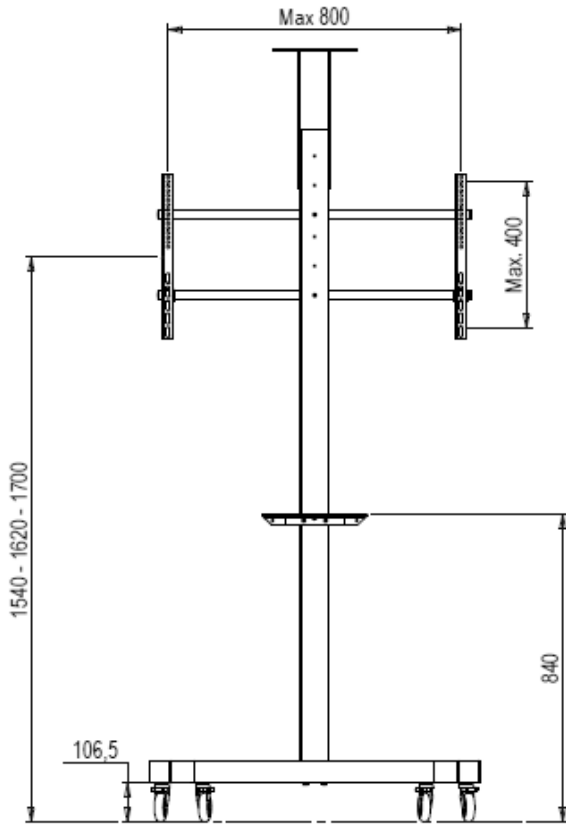

Max Screen Size: up to 90"
Max weight capacity: 80 Kg (lbs 176)
Min VESA 200x200
Max VESA 800x400

Showed measurements in mm

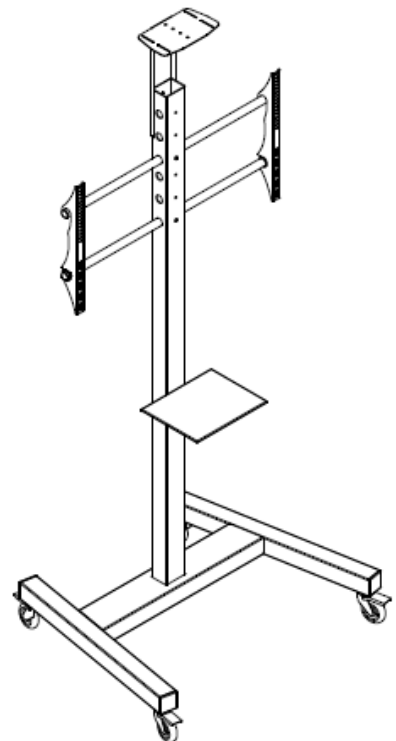



Important safety instruction

I - AVVERTENZA

Durante il montaggio fare attenzione alle istruzioni per l'uso e l'installazione dello schermo al plasma. OMB declina ogni responsabilità per danni diretti, indiretti o conseguenti ad una installazione errata e/o eseguita da persone inesperte, al montaggio su strutture non sufficientemente robuste, a modifiche, ad un impiego diverso da quanto indicato, a sovraccarichi, ad interventi non previsti dalle istruzioni per l'uso, all'abbinamento di supporti ed accessori non di marca OMB o ad eventuale combinazione di prodotti OMB non idonei a quella installazione. 1. Prima dell'uso controllare che tutti i dadi e bulloni siano fissati saldamente. 2. Utilizzare il carrello solamente su superfici piane. 3. Quando si sposta il carrello su una superficie non perfettamente piana, si consiglia di togliere il plasma dal carrello al fine di evitare eventuali danneggiamenti. 4. Per muovere il carrello si consiglia la massima cautela (almeno in due persone). 5. Portata massima del carrello: Kg. 80 (lbs 176)

GB - WARNING

During installation, the installation guide and the instructions for use which are supplied with the plasma screen itself must also be consulted. OMB is never responsible for direct, indirect or consequential damages which arise due to incorrect and/or inexperienced mounting, mounting on constructions which are not strong enough, modifications, use other than prescribed, overloading, not working in accordance with the instructions for use, combinations with other than OMB's products, unintended combinations of OMB's products. 1. Before use, check if all bolts and nuts are tightened up securely. 2. Use this trolley only on horizontal and stable floors. 3. When moving the trolley on an uneven floor, we advice to get the plasma display off the trolley to prevent damage. 4. Moving the trolley has to be done with great caution and at least 2 persons. 5. Maximum weight of the plasma display: Kg. 80 (lbs 176)

D - WARNUNG

Bei der Montage sind auch die Installations- und Verwendungsvorschriften für den Plasmabildschirm selbst zu beachten. OMB ist in keinem Fall verantwortlich für unmittelbare oder mittelbare Schäden bzw. Folgeschäden, die infolge einer fehlerhaften und/oder unsachgemäßen Montage, einer Montage an Konstruktionen mit unzureichender Belastbarkeit, infolge von Modifikationen, vorschriftswidriger Verwendung, Überlastung, Nichtbeachtung der Betriebsanleitung, Kombinationen mit nicht von OMB's stammenden Produkten oder bestimmungswidrigen Kombinationen der Produkte von OMB's auftreten. 1. Kontrollieren Sie vor Gebrauch, ob alle Befestigungsschrauben gut angeschraubt sind. 2. Dieser Trolley ist nur auf horizontalen und stabilen Flächen zu gebrauchen. 3. Während des Fahrens des Trolleys über eine unebene Fläche empfehlen wir, um den Plasmabildschirm vom Trolley zu nehmen. 4. Das Fahren des Trolleys sollte immer mit größter Vorsicht und mit minimal 2 Personen geschehen. 5. Maximales Gewicht des Plasmabildschirmes: Kg. 80 (lbs 176)

F - AVERTISSEMENT

Lors du montage, les prescriptions d'installation et d'utilisation de l'écran à plasma doivent également être observées. OMB's n'est jamais responsable des dommages directs ou indirects résultant d'un montage incorrect et / ou mal réalisé, d'un montage sur des constructions trop peu solides, d'une utilisation à des fins autres que celles prescrites, d'une surcharge, d'une utilisation non conforme au mode d'emploi, de combinaisons avec d'autres produits OMB's ou des combinaisons involontaires de produits OMB's. 1. Contrôler avant usage que toutes les vis de fixation sont bien serrées. 2. Ce chariot ne peut être utilisé que sur sols horizontaux et bien plans. 3. Lors du déplacement du chariot sur une surface irrégulière, nous conseillons de séparer l'écran plasma du chariot. 4. Le déplacement du chariot doit toujours s'effectuer très soigneusement par 2 personnes au minimum. 5. Poids maximal de l'écran plasma: Kg. 80 (lbs 176)

E - ADVERTENCIA

Durante la instalación han de observarse también las instrucciones de montaje y de uso de la propia pantalla de plasma. OMB's no será responsable de daños directos, indirectos o daños consecuenciales que resulten del montaje incorrecto y/o inexperto, del montaje en construcciones no suficientemente resistentes, de modificaciones, de una utilización no prevista en las instrucciones de uso, de sobrecargas, de trabajar sin observar el modo de empleo, de combinaciones con otros productos de OMB's o de combinaciones no intencionadas de productos de OMB's. 1. Antes de su uso, controle si todos los tornillos de fijación están bien sujetos. 2. Este trolley usarlo solo en suelos estables y horizontales. 3. Durante el desplazamiento del trolley en suelos irregulares, aconsejamos retirar la pantalla de plasma del trolley. 4. Para el desplazamiento debe realizarse siempre con mucho cuidado y por 2 personas como mínimo. 5. Máximo peso de la pantalla de plasma de: Kg. 80 (lbs 176)

P - AVISO

Durante a montagem, devem também ser respeitadas as instruções de instalação e de utilização da própria tela de plasma. A OMB's nunca é responsável por danos diretos, indiretos, ou causados por uma montagem incorreta e/ou incompetente, uma montagem em construções insuficientemente resistentes, modificações, utilização diferente da prevista, sobrecarga, não trabalhar segundo as instruções de utilização, combinações com outros produtos que não sejam da OMB's, combinações despropositadas de produtos da OMB's. 1. Antes do uso, verificação se todos os parafusos forem apertados acima de firmemente. 2. Use este trolley somente em assoalhos horizontais e estáveis. 3. Ao mover o trolley num assoalho desigual, nós conselho de retirar a pantalha de plasma do trolley para prevenir danos. 4. Mover o trolley tem que ser feito com grande cautela e pelo menos 2 pessoas. 5. Peso máximo da pantalha de plasma: Kg. 80 (lbs 176).

NL - WAARSCHUWING

Bij de montage dienen ook de installatie- en gebruiksvorschriften van het plasmascherm zelf in acht genomen te worden. OMB is nooit verantwoordelijk voor directe, indirecte of gevolgschade als gevolg van foutieve en/of ondeskundige montage, montage aan onvoldoende sterke constructies, modificaties, gebruik anders dan voorgeschreven, overbelasting, niet werken volgens de gebruiksaanwijzing, combinaties met andere dan OMB's producten, onbedoelde combinaties van OMB's producten. 1. Controleer voor gebruik of alle bevestigingsbouten goed vast zitten. 2. Deze trolley alleen op horizontale en stabiele ondergronden gebruiken. 3. Tijdens verrijden van de trolley over een niet oneven ondergrond adviseren wij om de plasma display van de trolley te verwijderen. 4. Verrijden dient altijd met grote voorzichtigheid te gebeuren en met minimaal 2 personen. 5. Maximaal gewicht plasma scherm Kg. 80 (lbs 176)



PARTS

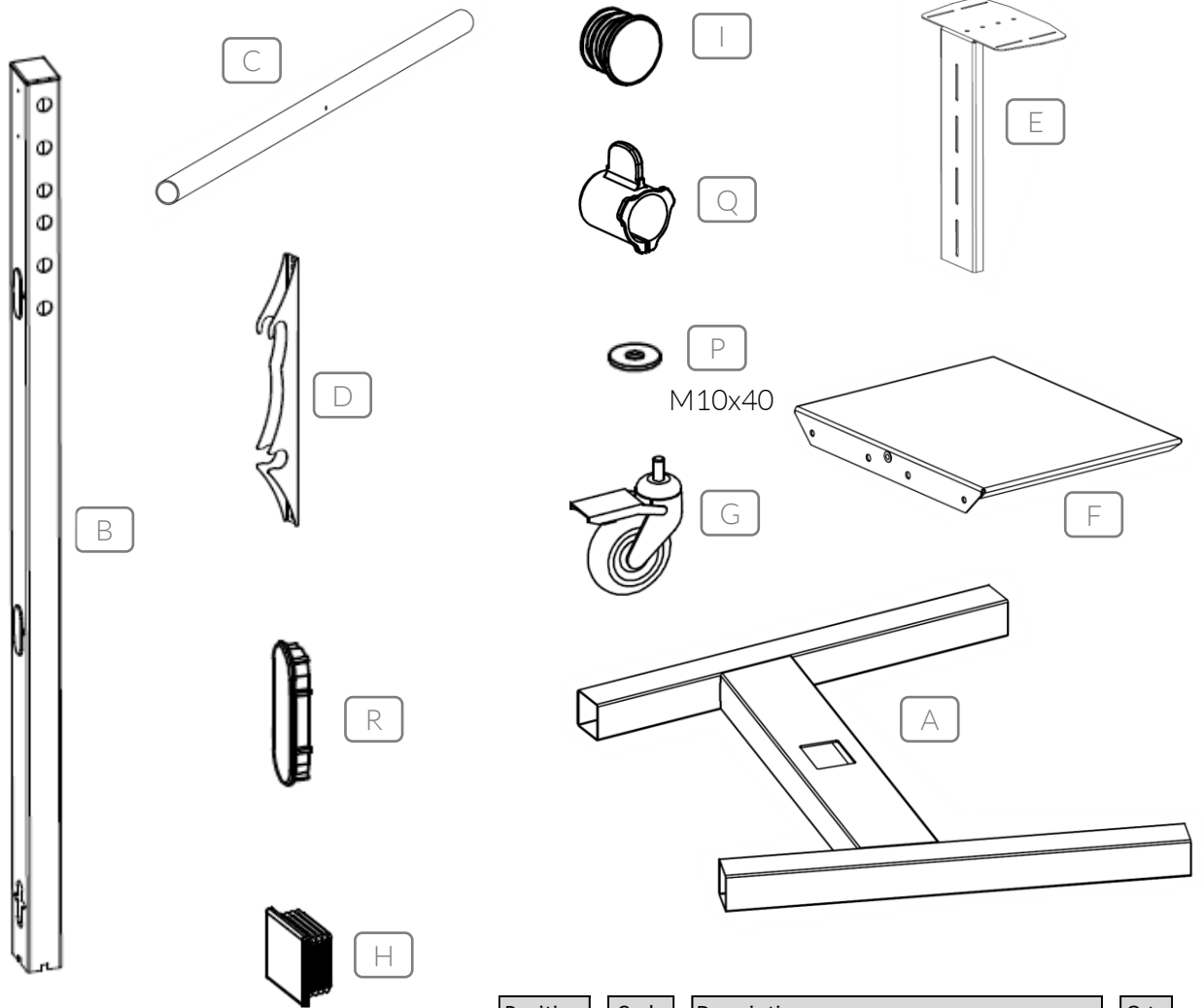

O
M10



L
M8x20



S
M8x12



M
M5x20



T
M8x20



N
M5x10

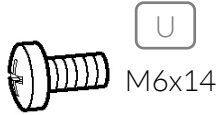

U
M6x14

Position	Code	Description	Q.ty
A	44446	BASE	1
B	44452	MAIN TUBE	1
C	02183	GALVANIZED SCREEN SUPPORT 844 mm	2
D	43742	MONITOR BRACKET	2
E	44455	WEBCAM SHELF	1
F	43734	CENTRAL SHELF	1
G	02519	WHEEL WITH BRAKE M10x20	4
H	03601	CAP 60x60	4
I	31881	CAP d.25 BLACK	4
L	00892	SCREW M8x20	4
M	02310	SCREW M5x20	2
N	00961	SCREW M5x10	4
O	00812	NUT M10	8
P	02545	WASHER M10x40	8
Q	32237	SCREEN STOP	2
R	02242	OVAL CAP	3

Position	Code	Description	Q.ty
S	02331	SCREW M8x12	4
T	02312	SCREW M8x20	4
U	01810	SCREW M6x14	4



ASSEMBLY PROCESS

Wheels assembly

Insert wheel G with washer P into the hole in the base.

Insert a washer P inside the tube and screw 2 nuts O. Repeat the operation for all wheels

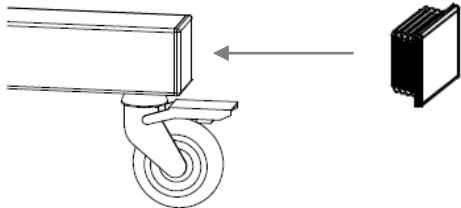
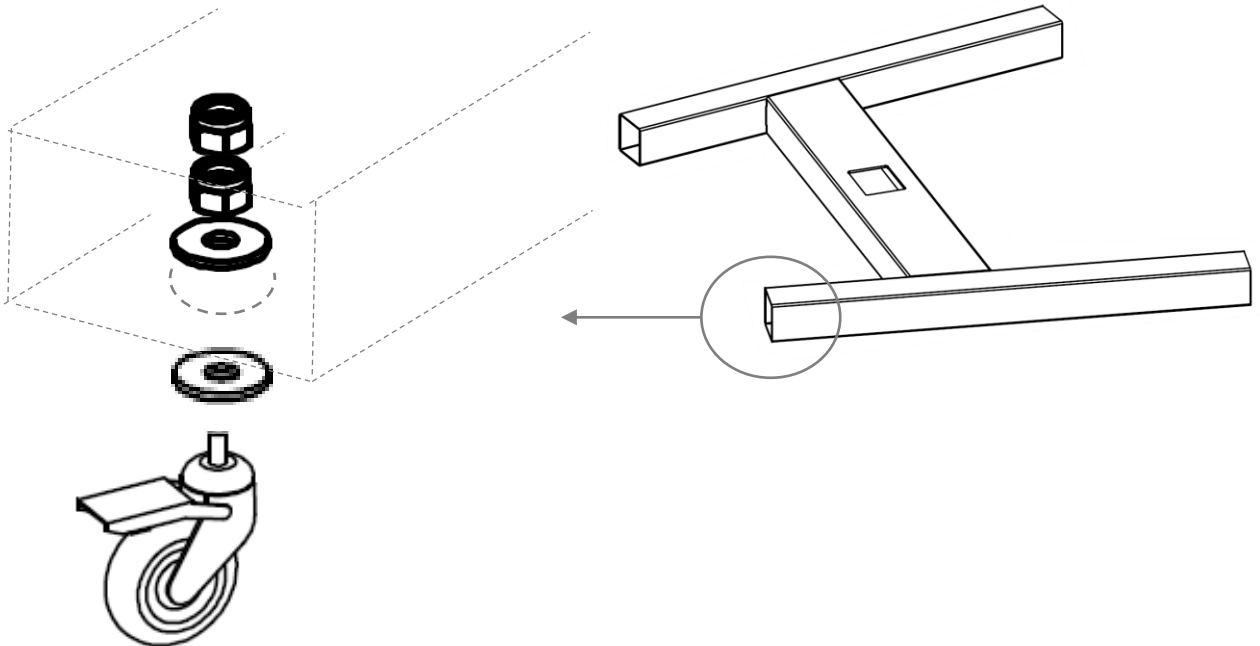

Insert all caps H on the ends of the base tubes

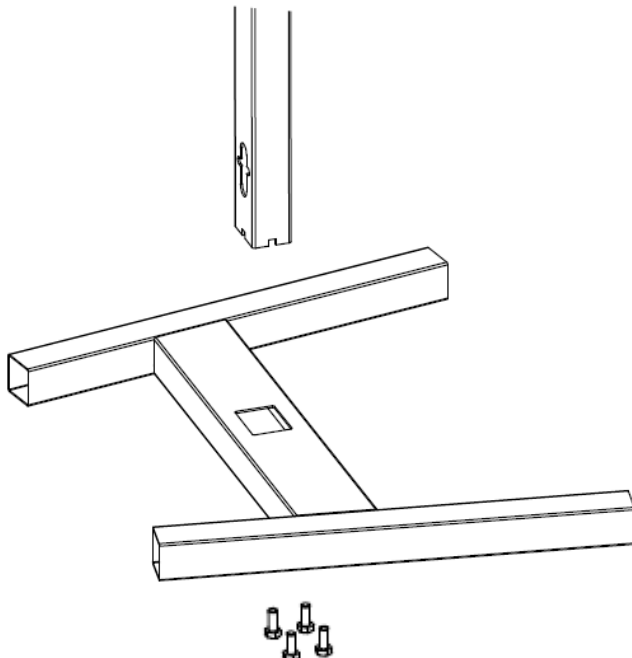

Main tube assembly

Insert pole B into base A and
screw the 4 fixing screws L under the base



ASSEMBLY PROCESS

Insert the 2 bars C inside the holes of column B.
Choose which of the holes to insert the two bars according to the VESA of your monitor and the desired height.
Then fix the two bars with the M screws.

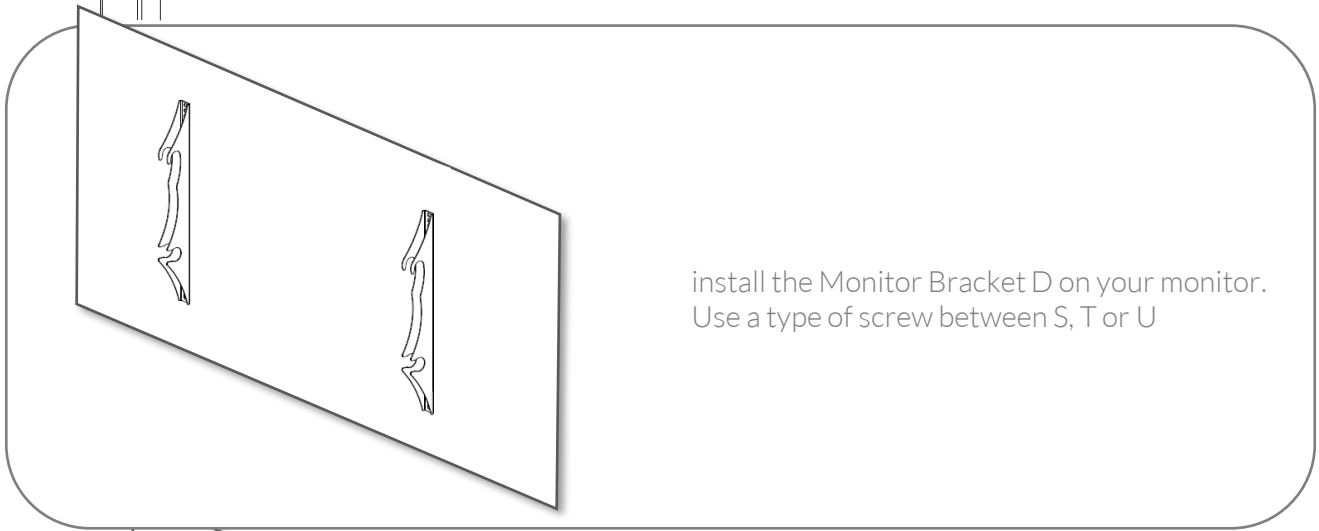
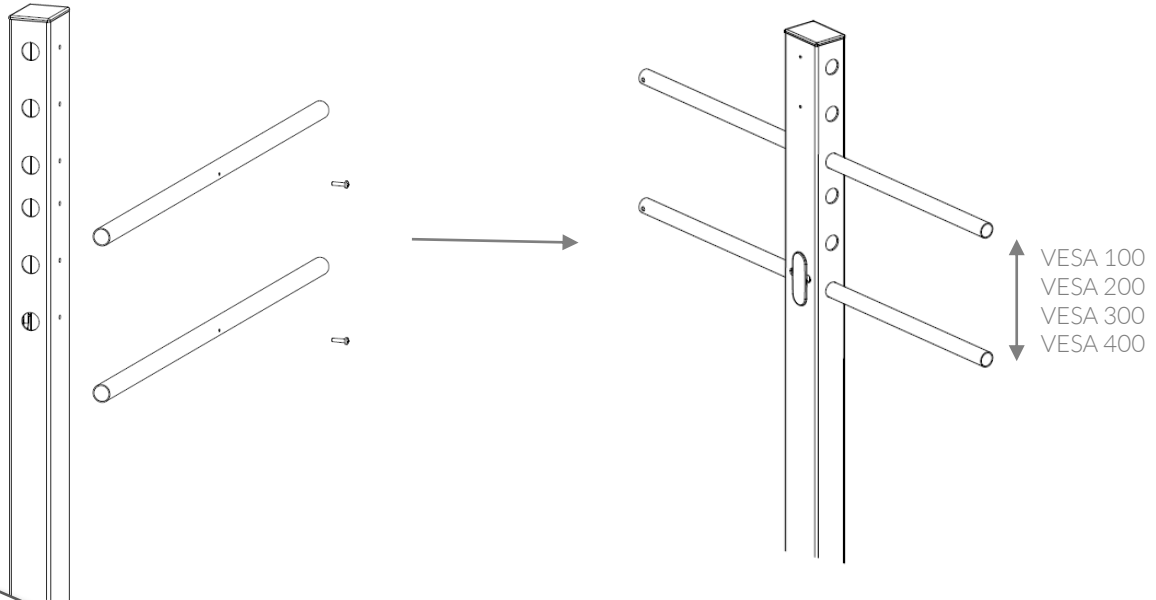

install the Monitor Bracket D on your monitor.
Use a type of screw between S, T or U

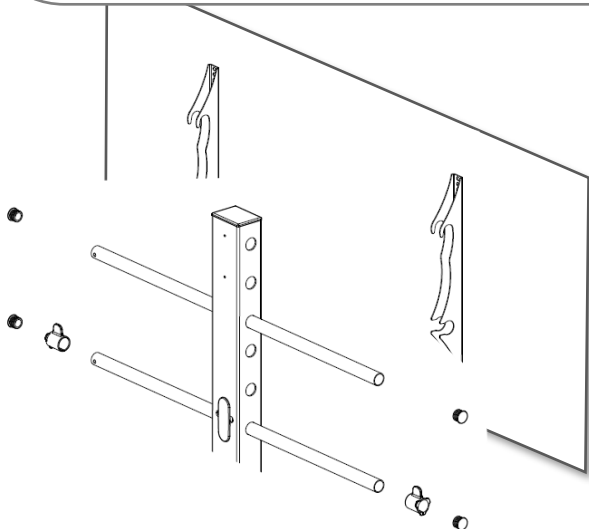

insert the monitor lock Q which
must remain outside the Monitor Bracket D.
Then insert the caps I on the ends of the tubes C



ASSEMBLY PROCESS

Fix the shelf E and F with the screws N

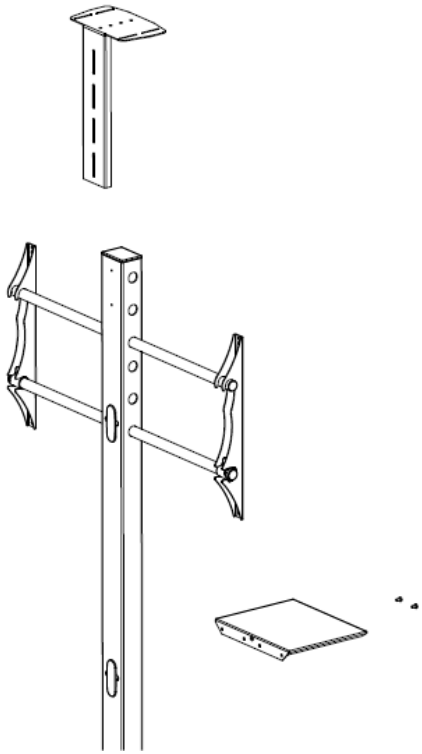

Insert the cables of your monitor inside the tube B through the oval holes and then cover the holes with the cap R

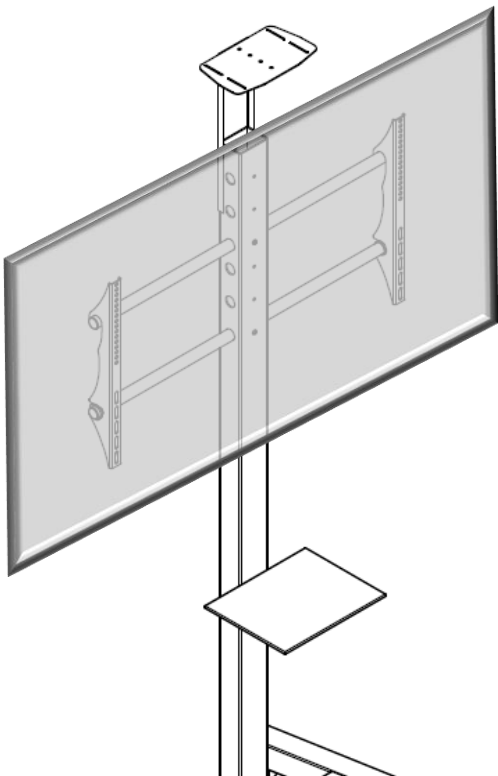
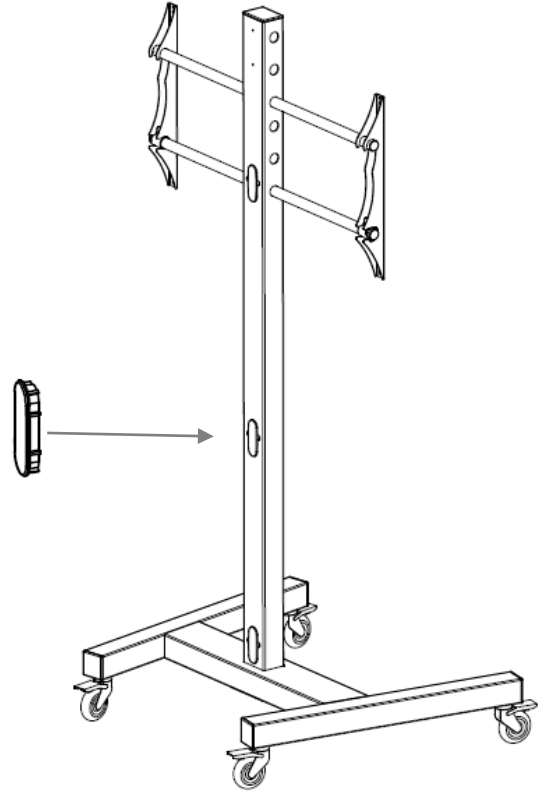

Install the screen on the FIX TROLLEY