

|           |      |                                  |   |   |   |   |   |
|-----------|------|----------------------------------|---|---|---|---|---|
| 1         | 2    | 3                                | 4 | 5 | 6 | 7 | 8 |
| REVISIONS |      |                                  |   |   |   |   |   |
| ISS       | ZONE | DESCRIPTION \ PER REQUEST \ DATE |   |   |   |   |   |
| V         | OPEN | Open drawings to customers       |   |   |   |   |   |

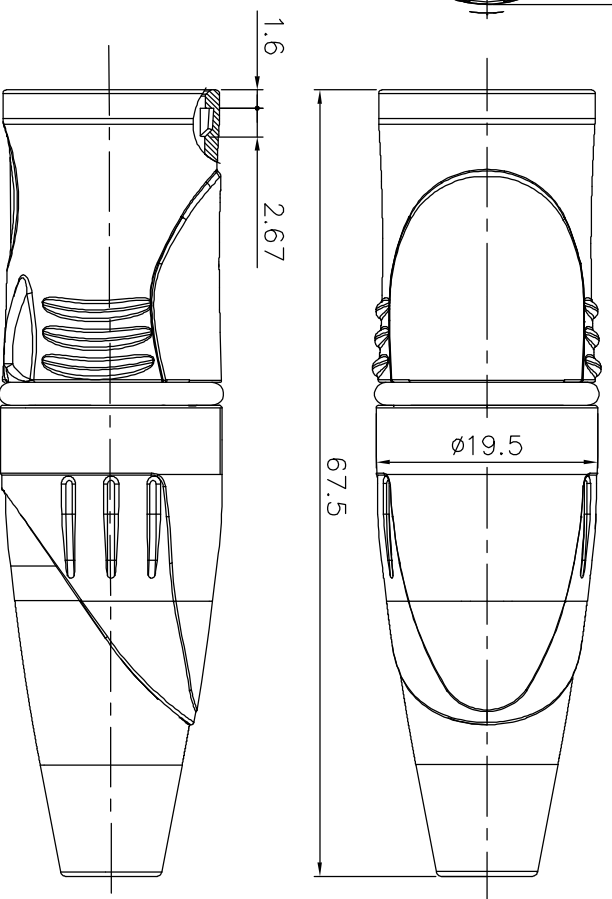
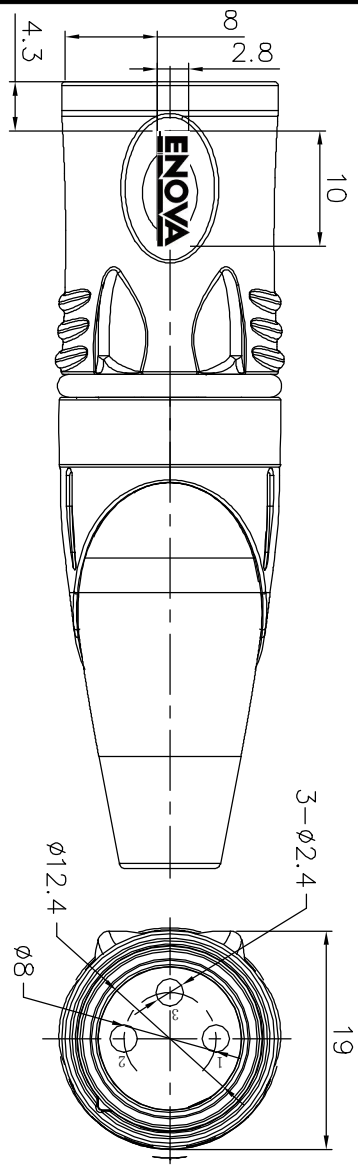
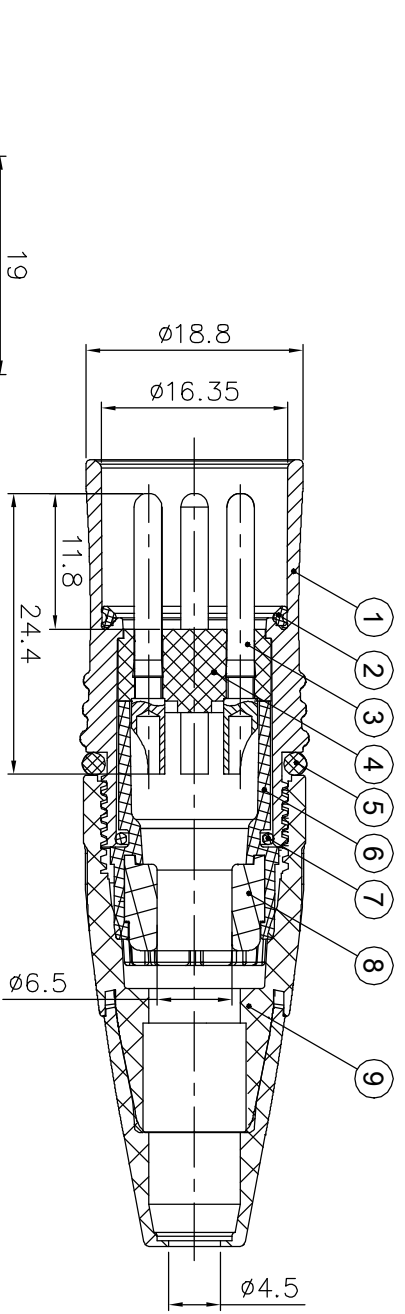

|   |                |          |                         |   |  |
|---|----------------|----------|-------------------------|---|--|
| 9 | CAP+BOOT       | PA6+TPR  | BK+OR                   | 1 |  |
| 8 | WATERPROOF     | NBR      | BLACK                   | 1 |  |
| 7 | O-WASHER       | NBR      | BLACK                   | 1 |  |
| 6 | CABLE CLAMP    | PA6      | WHITE                   | 1 |  |
| 5 | O-WASHER       | SILICON  | BLACK                   | 1 |  |
| 4 | INSULATOR      | PA       | BLACK                   | 1 |  |
| 3 | PIN            | H59-1    | SILVER                  | 3 |  |
| 2 | O-WASHER       | SILICON  | ORANGE                  | 1 |  |
| 1 | DIE-CAST SHELL | ZZnAL4-1 | Electro-coating (black) | 1 |  |

|                                       |       |           |                                  |
|---------------------------------------|-------|-----------|----------------------------------|
| DIMENSIONS ARE IN MILLIMETERS         |       | APPROVED  | DATE                             |
| UNLESS OTHERWISE SPECIFIED TOLERANCES |       | CHECKED   | DATE                             |
| ANGLES = ±5°                          |       | DRAWN     | DATE                             |
| UP TO 6 = ±0.2                        |       | HUHAONAN  | 2019-8-27                        |
| 6-40 = ±0.4                           |       | FILE NO.  |                                  |
| 40-120 = ±0.6                         |       | ERP LINK: |                                  |
| 120-315 = ±1                          |       | PART NO.  | XL23MB-W                         |
| ABOVE 315 = ±1.6                      |       | TITLE     | Connector Distribution GmbH      |
| THIRD_ANGLE                           | SCALE | 1.5/1     | WATERPROOF 3P XLR MALE CONNECTOR |
|                                       |       |           | PLATED SILVER PIN                |

|     |             |          |        |      |             |
|-----|-------------|----------|--------|------|-------------|
| NO. | DESCRIPTION | MATERIAL | FINISH | Q'TY | DRAWING NO. |
| 1   |             |          |        |      |             |